

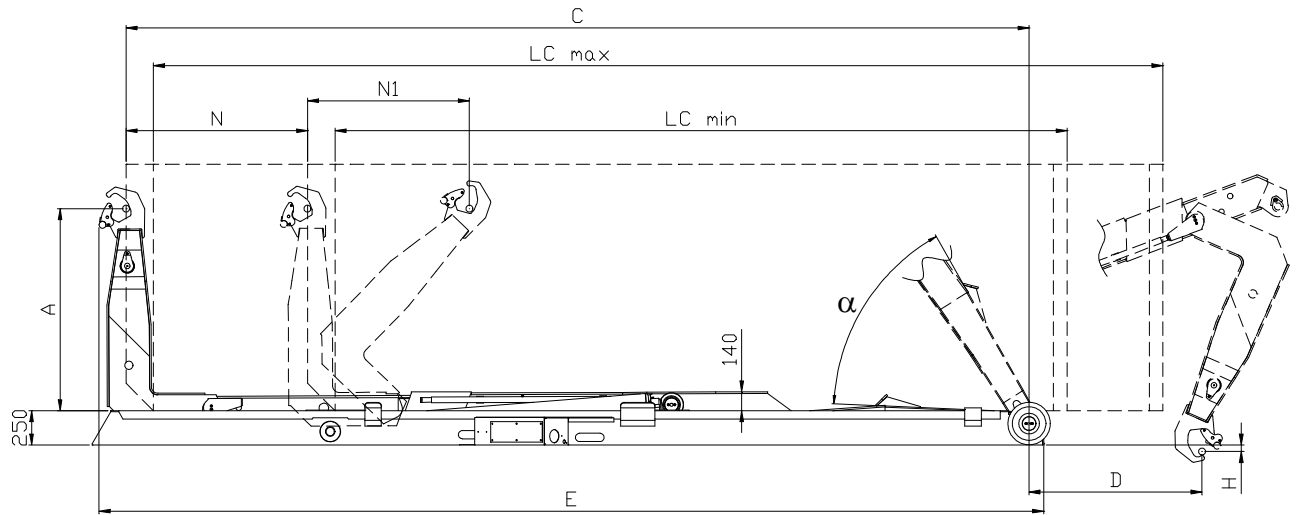

srl

POLYLIFTE TECHNICAL PARTICULARS

T26 SN



LIFTING CAPACITY	26 T						
HOOKLIFT WEIGHT	3200		3300		3350		
TOTAL LENGTH (E)	5710	5910	6110	6260	6460	6660	6860
HOOK-ROLLER CENTRE DISTANCE (C)	5400	5600	5800	6000	6200	6400	6600
CONTAINER WORKING LENGTH (LC min)	3800			4200		4500	
CONTAINER WORKING LENGTH(LC max)	6000	6200	6400	6600	6800	7000	7200
HOOK HEIGHT (A)	1570						
CONTAINER PICKING UP HEIGHT (H)	-270		-170		-50		
HOOKARM STROKE (N)	825	1025	1225	1025	1225	1125	1325
HOOKARM STROKE (N1)	1180						
WIDTH OF THE FRAME	1060						
MAX TILTING ANGLE (α)	60°			58°			
LOADING ANGLE (max/min)*	41°/22°			39°/22°		41°/23°	
OPERATING PRESSURE (bar)	340			350			
PUMP DELIVERY / 1000 r (Lt / min)	60						
OIL TANK (Lt)	150						
CENTRE OF GRAVITY (Dimension referred to sliding roller centre)	3190	3200	3260	3385	3425	3460	3480

* truck height: 1100 mm.