



# TRANSFORMER

## MULTI KIT

---

THE **MULTI KIT MKZ SERIES**, WITH ITS QUICK CHANGING SYSTEM, IS A VERSATILE TOOL THAT IS ABLE TO FACE DIFFERENT WORKING CONDITIONS, WITHOUT CHANGING THE MAIN FRAME.

THANKS TO ITS INNOVATIVE AND QUICK HYDRAULIC CHANGING SYSTEM IT IS POSSIBLE TO REPLACE AND COUPLE DIFFERENT DEMOLITION KITS, WITHOUT REMOVING THE STRUCTURAL PINS BY HAND.



# TRANSFORMER MULTI KIT

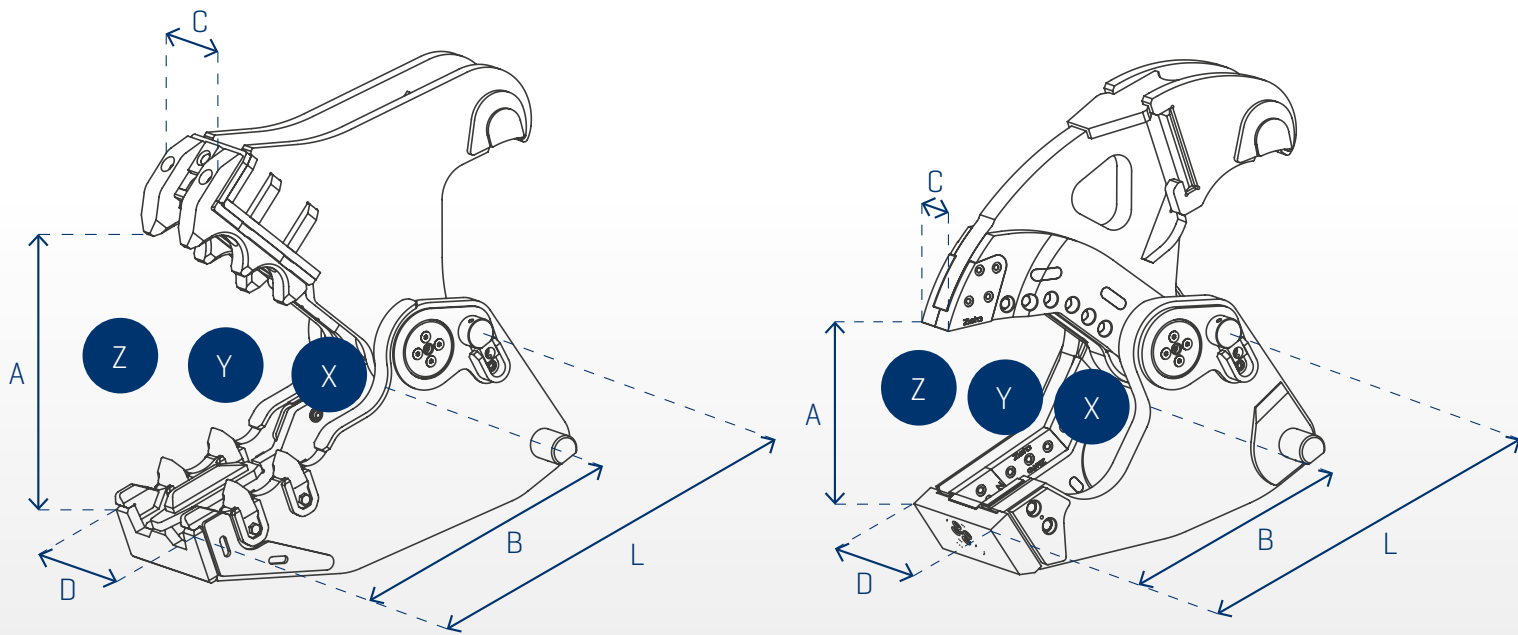

TECHNICAL DATA		MKZ + PULVERISER KIT			MKZ + SHEAR KIT		
		MKZ15	MKZ20	MKZ30	MKZ15	MKZ20	MKZ30
Total weight MKZ	Kg	1900	2500	3250	1900	2400	3100
A	mm	730	900	970	430	480	510
B	mm	710	800	870	535	575	600
C	mm	270	300	370	120	125	130
D	mm	400	450	550	365	390	440
L	mm	970	1070	1200	820	885	900
Force at tip Z	t	70	90	115	90	135	170
Central force Y	t	110	140	180	180	270	320
Force at blade X	t	230	260	315	410	580	750
Blade length	mm	200	240	240	520	560	600
Operating pressure	bar	320-380	320-380	320-380	320-380	320-380	320-380
Oil ow	l/min	200-250	250-300	250-350	200-250	250-300	250-350
Type of rotation		360° Hyd.	360° Hyd.	360° Hyd.	360° Hyd.	360° Hyd.	360° Hyd.
Rotation pressure	bar	140	140	140	140	140	140
Rotation flow	l/min	15	15	15	15	15	15
Rebar	mm	35	40	50	50	60	70
Excavator weight	t	18-26	24-38	38-52	18-26	24-38	38-52

Technical specification can be modified without any prior notice and without incurring in any obligation.

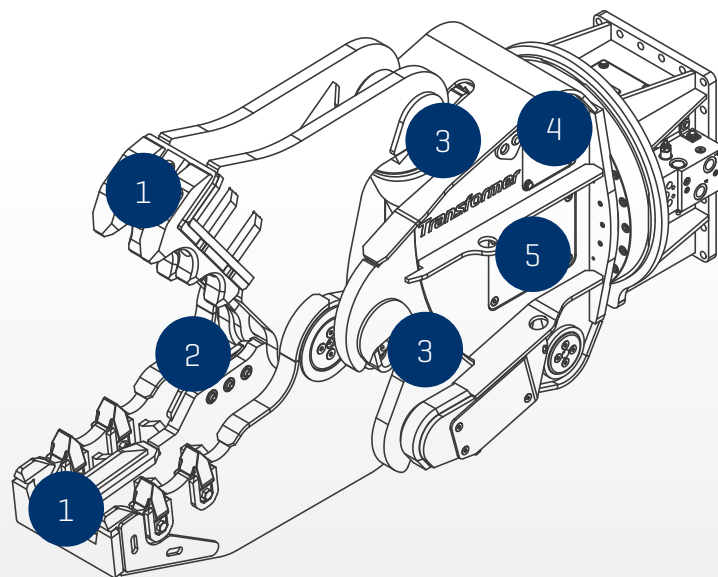
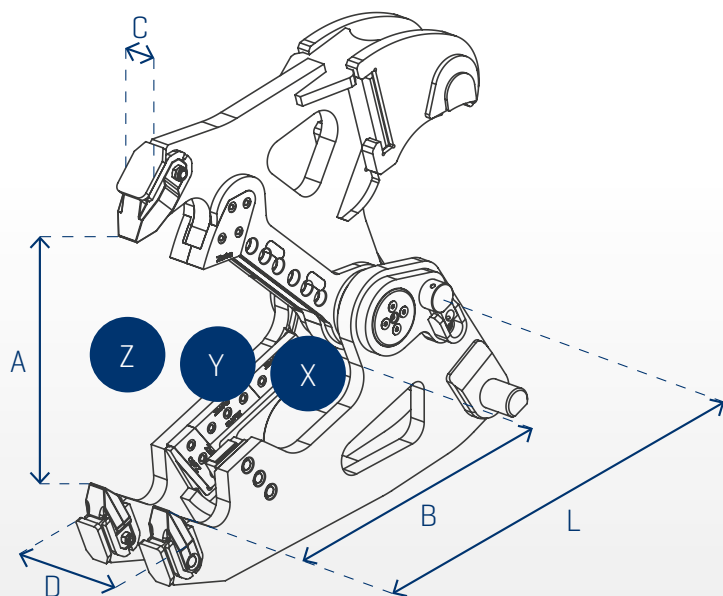

## MKZ + COMBICRUSH KIT

MKZ15	MKZ20	MKZ30
1900	2500	3250
740	815	880
750	810	870
125	125	135
345	360	400
1090	1140	1240
75	90	110
110	160	185
430	530	720
495	495	540
320-380	320-380	320-380
200-250	250-300	250-350
360° Hyd.	360° Hyd.	360° Hyd.
140	140	140
15	15	15
40	45	55
18-26	24-38	38-52

## SPECIFICATIONS

### MKZ + PULVERISER KIT

Cylinder fittings	SAE	3/4"
Rotation fittings	GAS	1/2"
Speed valve		YES
Interchangeable parts		Teeth + plate

### MKZ + PULVERISER KIT

Cylinder fittings	SAE	3/4"
Rotation fittings	GAS	1/2"
Speed valve		YES
Interchangeable parts		Blade

### MKZ + COMBICRUSH KIT

Cylinder fittings	SAE	3/4"
Rotation fittings	GAS	1/2"
Speed valve		YES
Interchangeable parts		Blade

Multi kit length 1230 mm

## KEY FEATURES

### 1 - Interchangeable parts:

All parts subjected to wear can be replaced to restore the efficacy of the tool to 100%.

### 2 - Blade with 4 profiles:

The blade is large and it can be turned to refurbish the cutting profile.

### 3 - System of change:

The pin remains into the cylinder.

### 4 - Speed valve.

### 5 - Compact:

Small-sized, excellent visibility during maneuver.





## Zato srl

Via Campi Grandi, 23  
25080 Prevalle (BS) - Italy

Tel. +39 030 6461800  
Fax +39 030 6801897  
e-mail info@zato.it